

Bologna – 31 July 2021

# Waste to Energy installation (1500 Tpd)



[www.eemaxx.it](http://www.eemaxx.it)

# AGENDA

---



- Company Profile



- Combustion



- Technology – process



- Project References

# Multi-stage combustion

Horizontal

1. Drying
2. Gasification
3. Burn-out

Vertical

4. Gas combustion
5. Gas burn-out

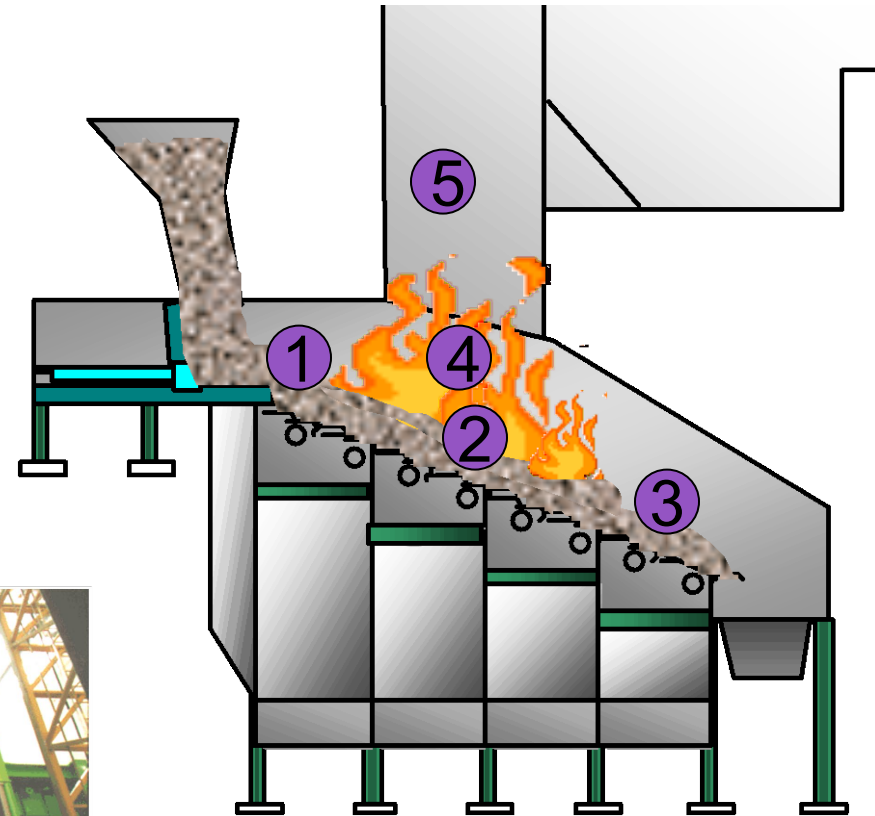

# The true multi-stage grate

In a consequent way the incineration process is 'staged'  
Combustion happens above the grate instead of on the grate

## **Benefits**

- Higher throughput or lower investment/ton
- Higher steaming rate (less excess air)
- Better emissions (CO, NOx)
- Lower maintenance cost (lower tile temperatures increase tile life)

# Different combustion phases

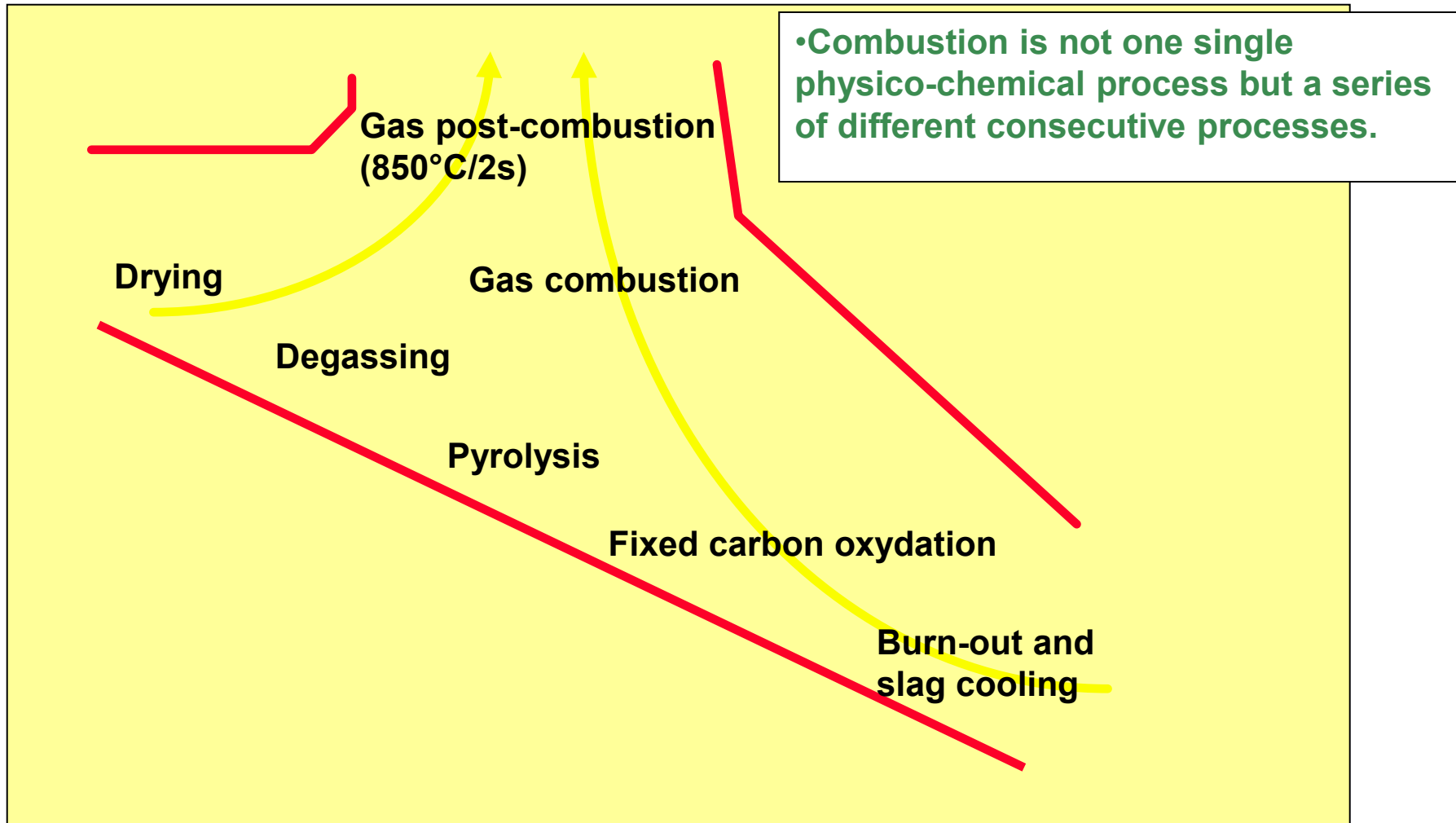

# Description

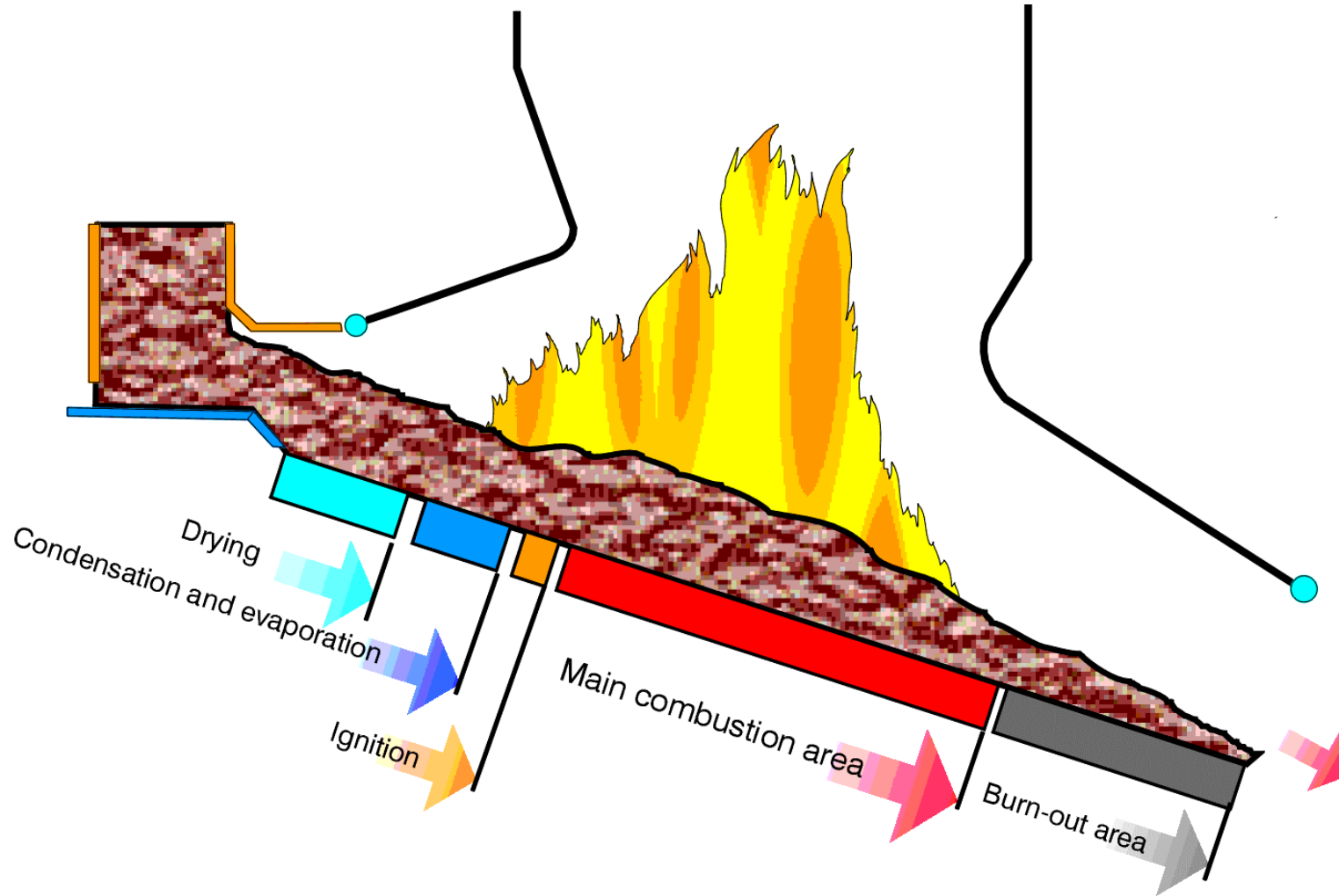

# Process flow scheme

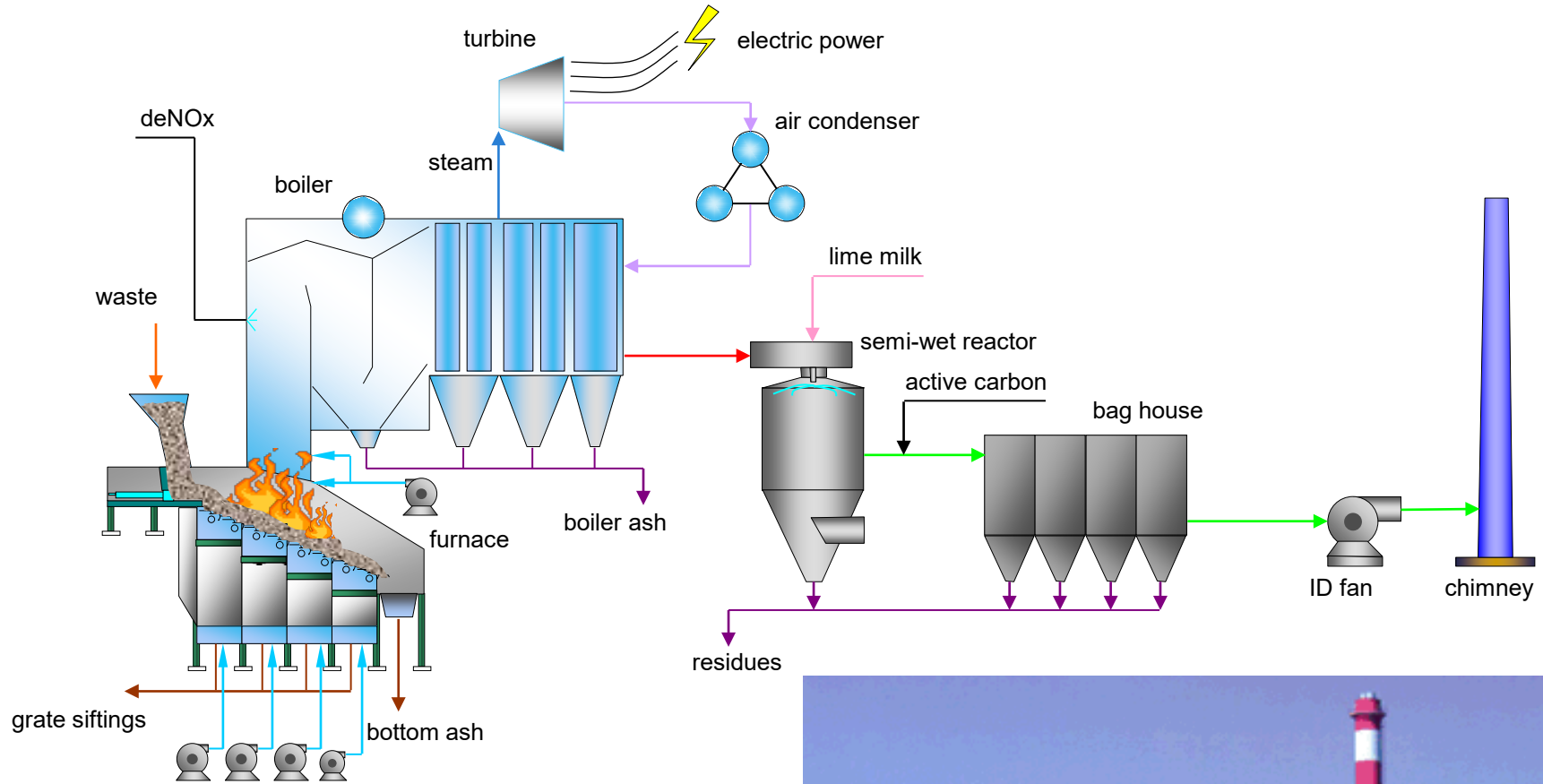



# Feeding hopper and shut-off flap

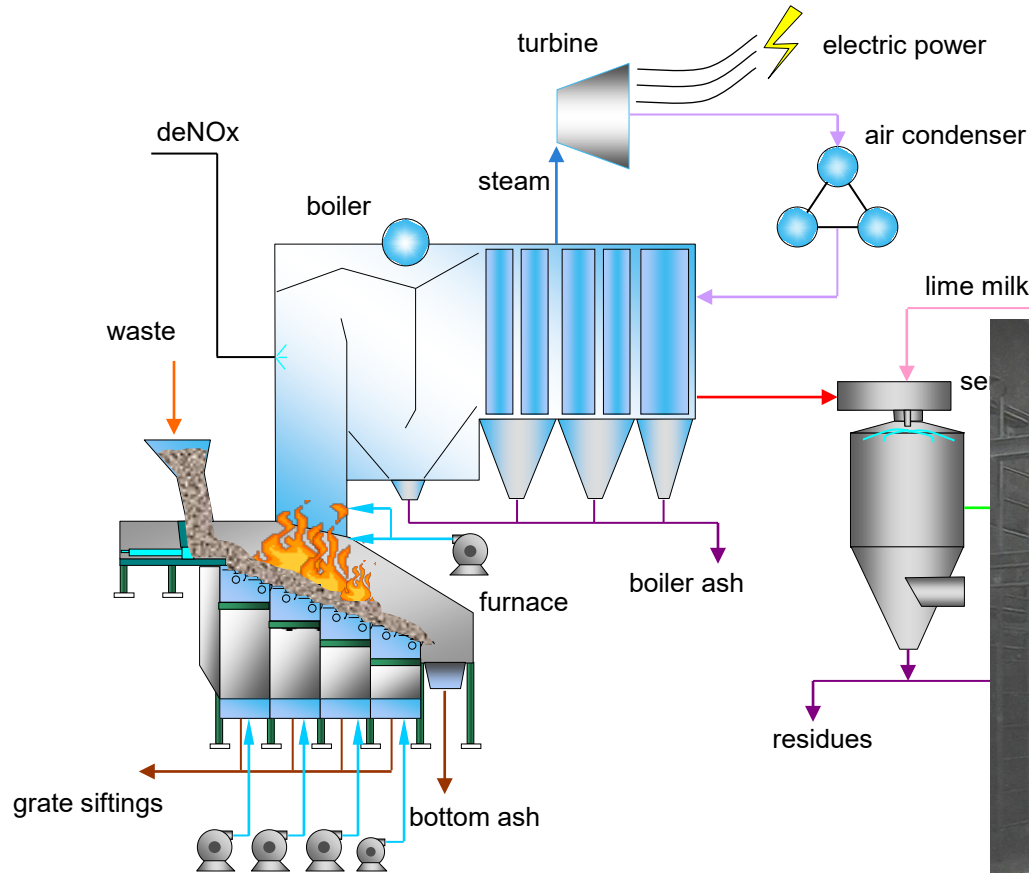

## Features

- Straightforward construction
- Electromechanical drive
- No contact with waste
- fail-safe closing system

## Advantages

- Reduced investment
- Limited power consumption
- Less wear and maintenance
- Safety



# Feeding chute and compensator

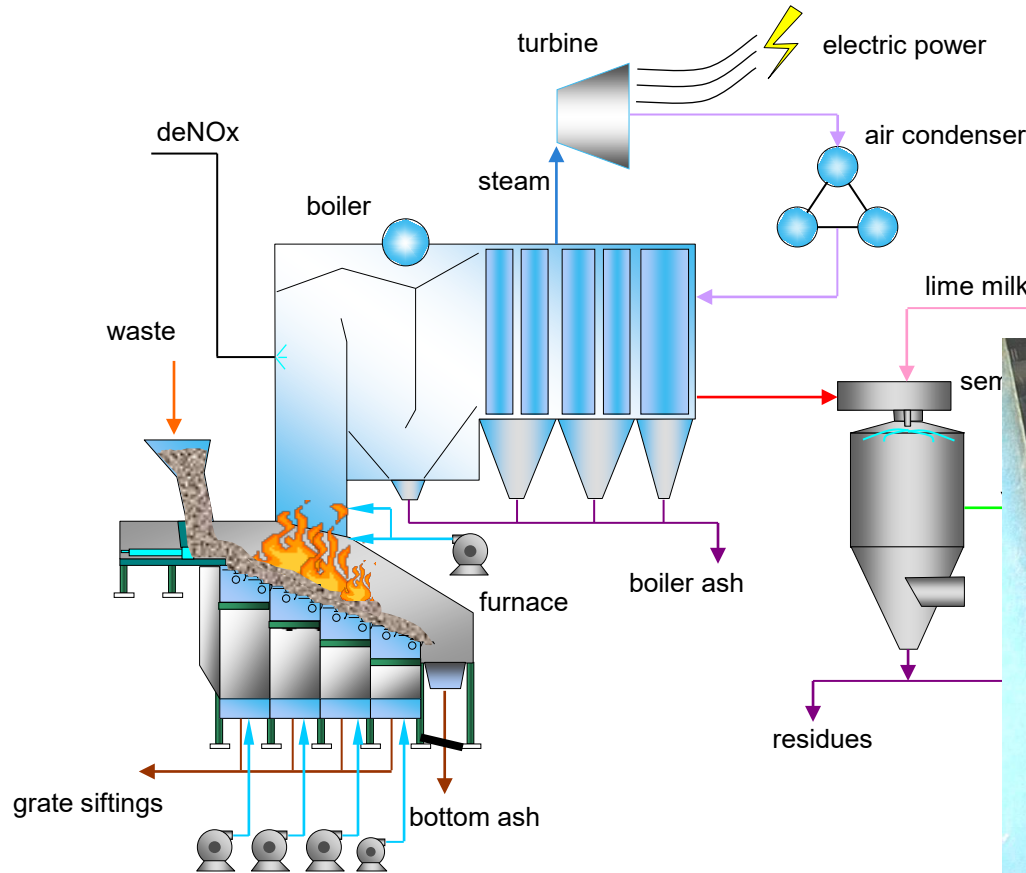

## Features

- Water-cooled chute, active cooling
- 'Cold' compensator
- Constructed in wear resistant material
- Robust construction

## Advantages

- Safety
- Airtight, reliable
- Reduced maintenance costs
- Long life time

# Multi-stage grate

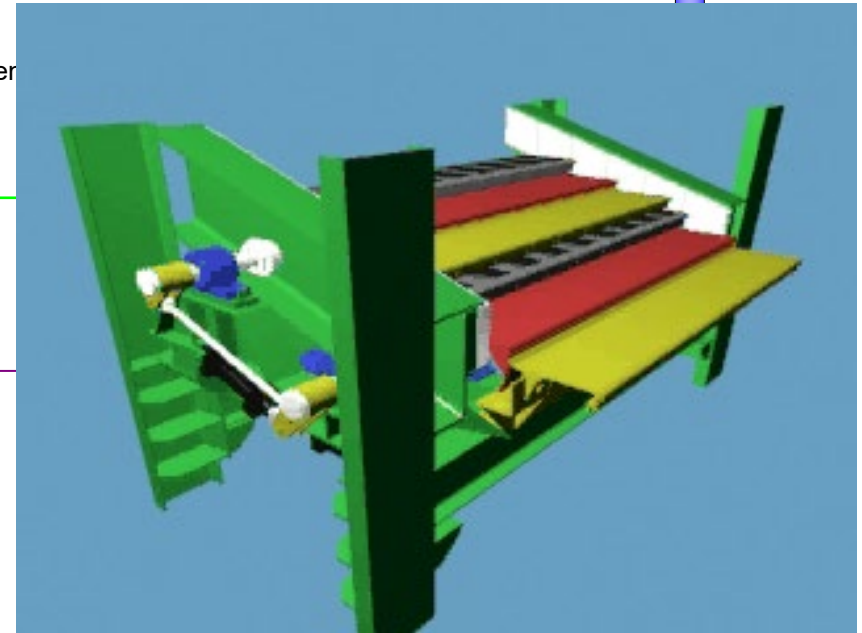
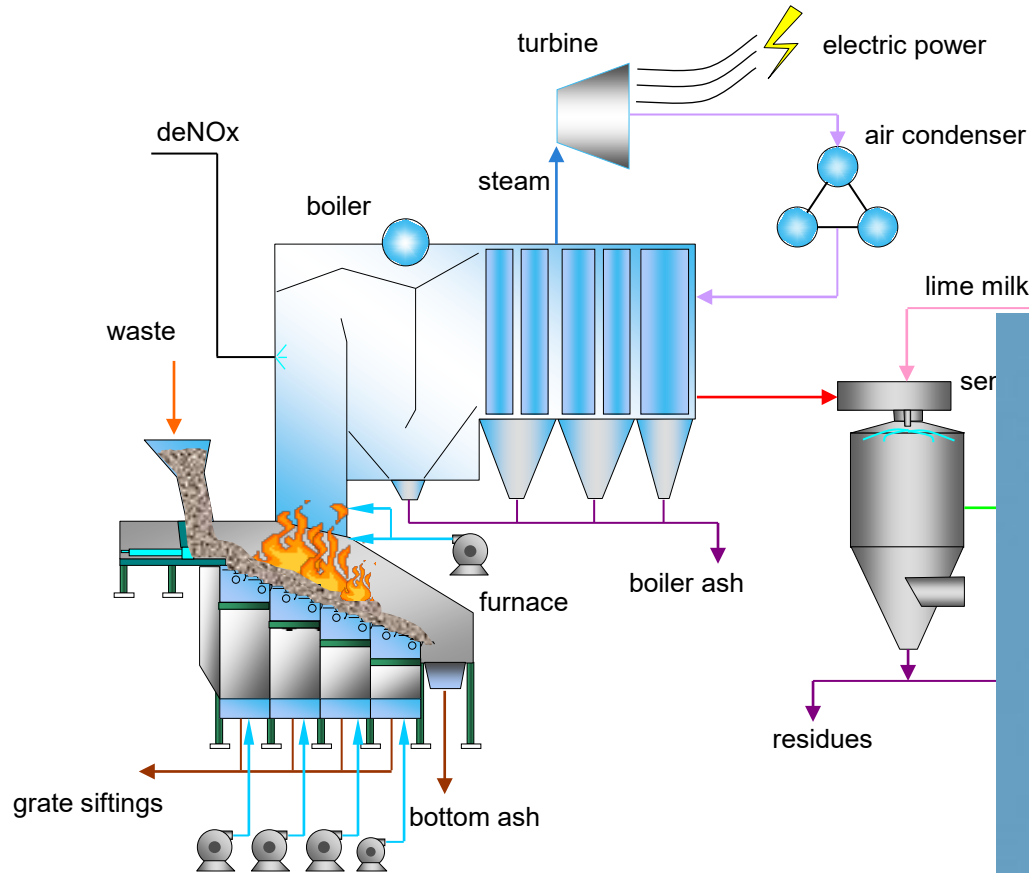

## Features

- Modular construction
- Multi-stage
- Independent double motion control
- Special tile construction

## Advantages

- Shortest erection time
- Best control leads to high throughputs
- Controlled combustion, good burn-out
- Long life time, reduced maint. costs

# Ash extractor

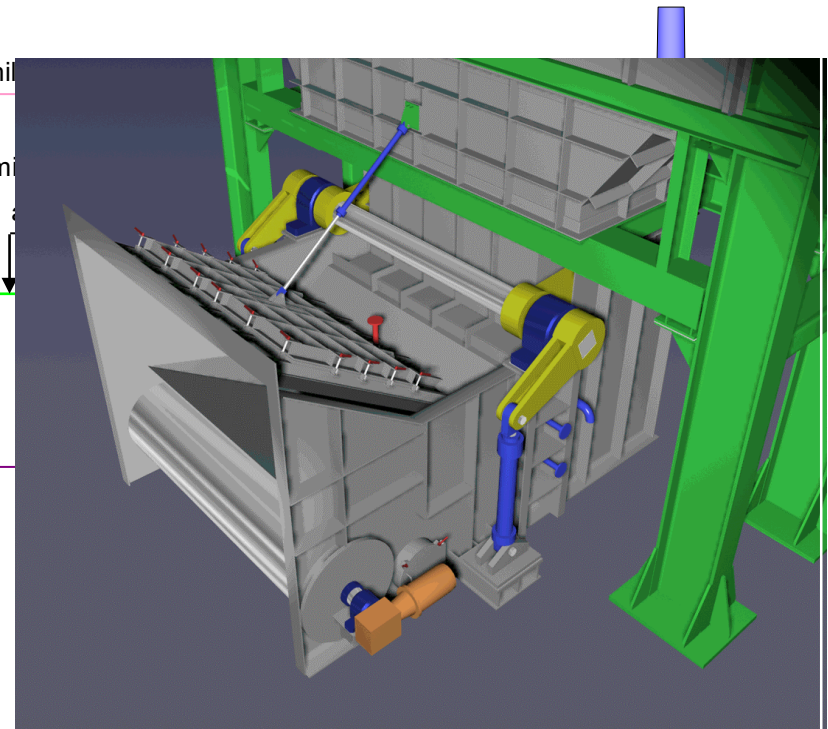
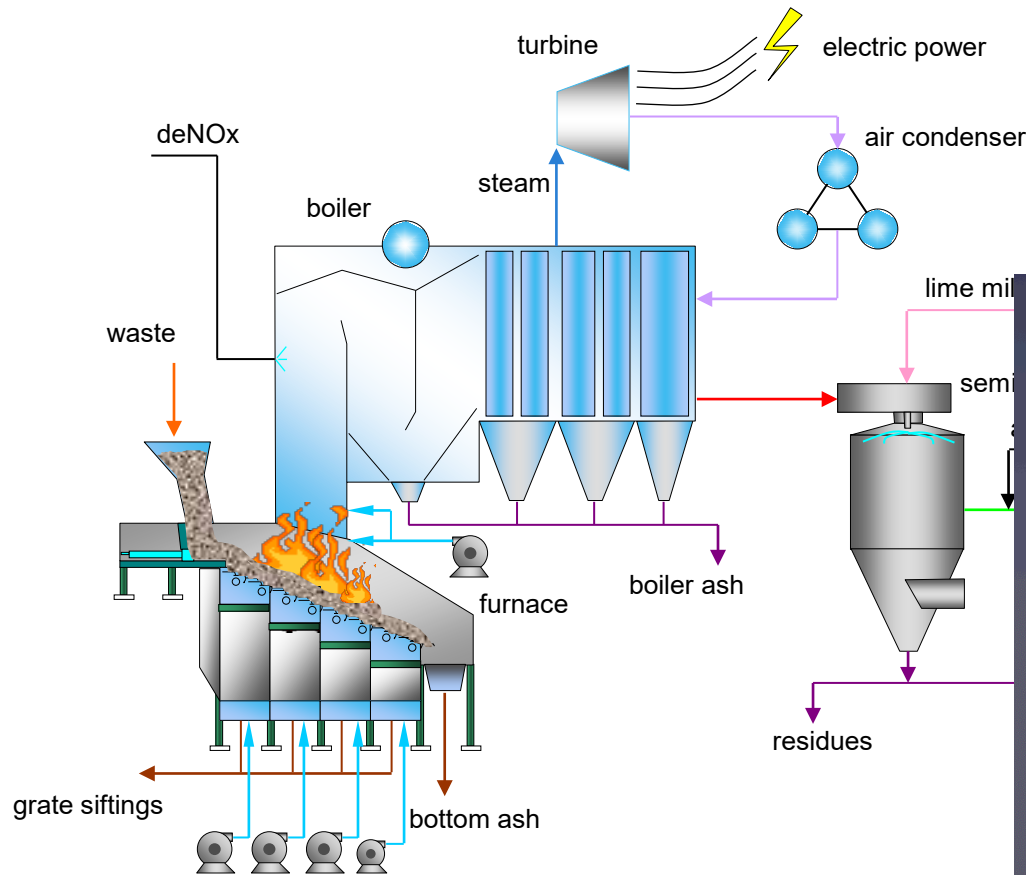

## Features

- Equal torque distribution
- Less friction
- Robust

## Advantages

- Less power consumption
- Less wear
- Reliable

# DeNOx SNCR

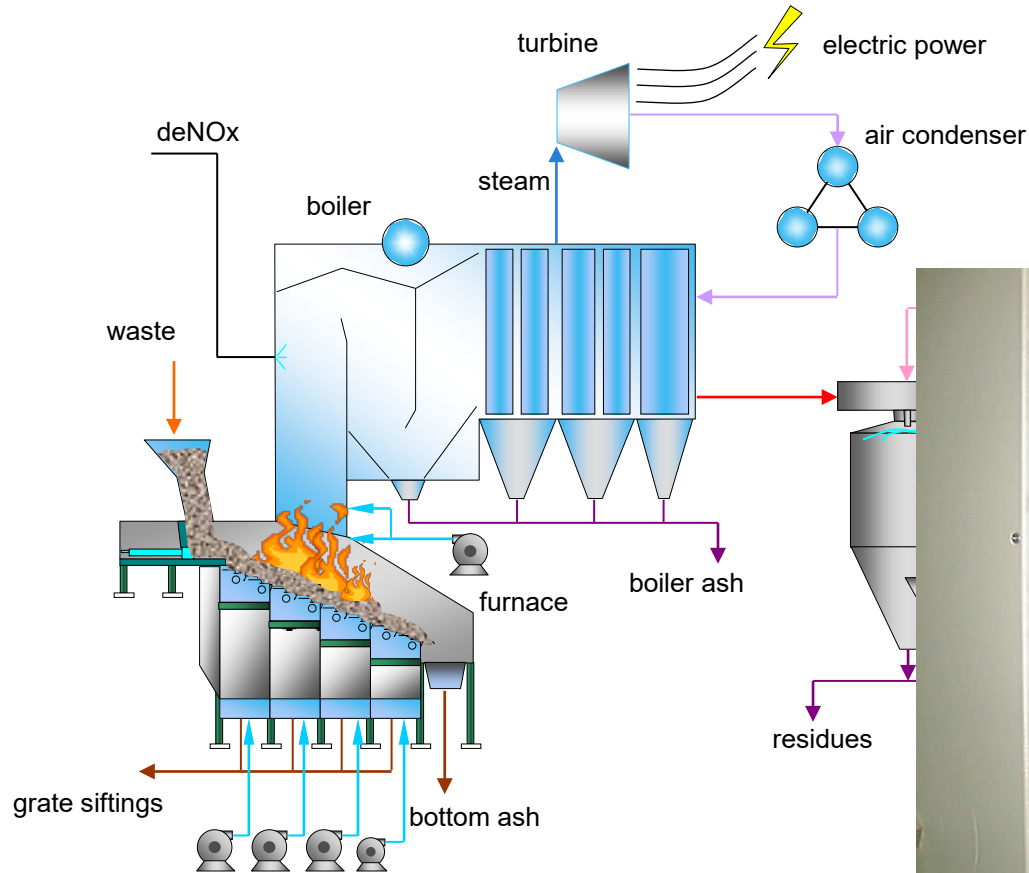

## Features

- Non-catalytic
- Controlled injection at several levels
- High temperature NOx reduction

## Advantages

- Reduced investment cost
- Min. reaction product consumption
- Reduced energy consumption



# Combustion air

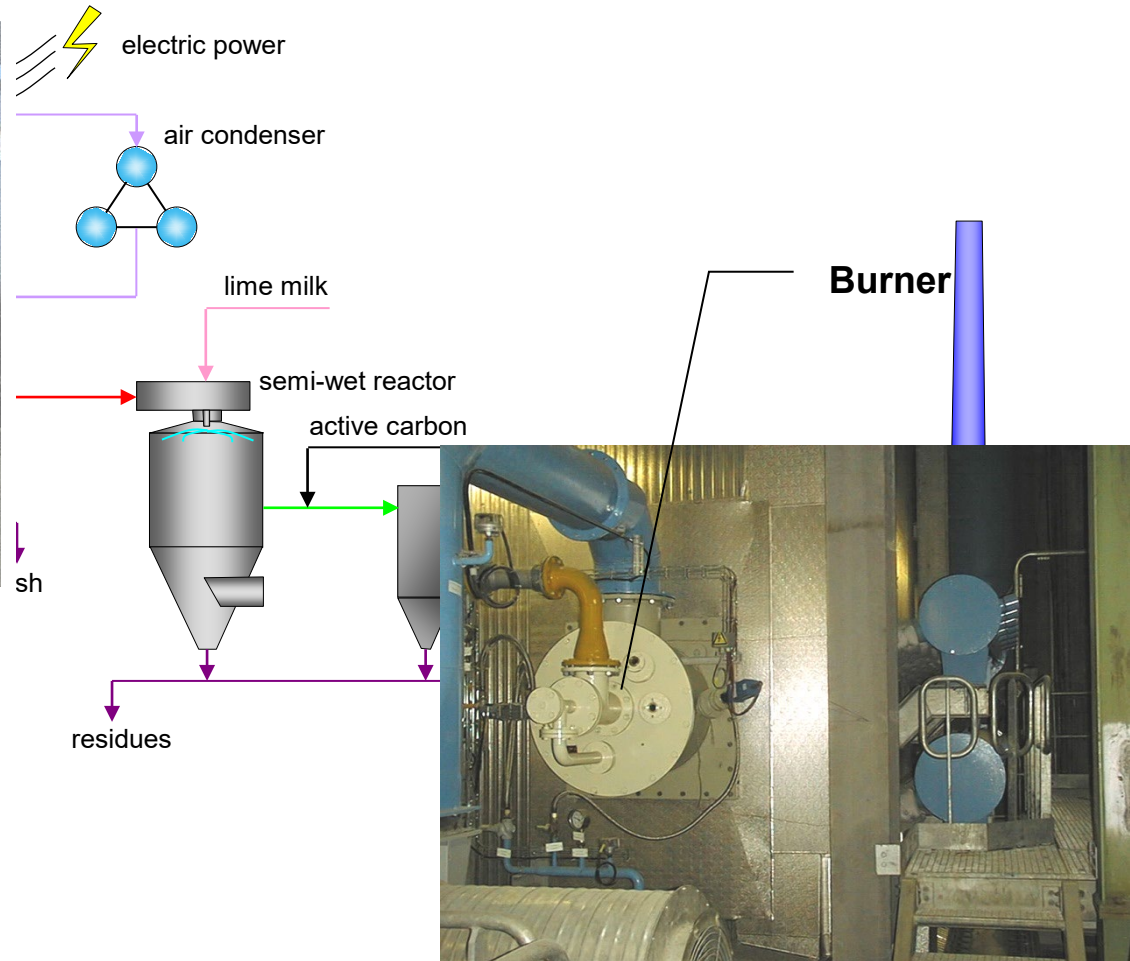
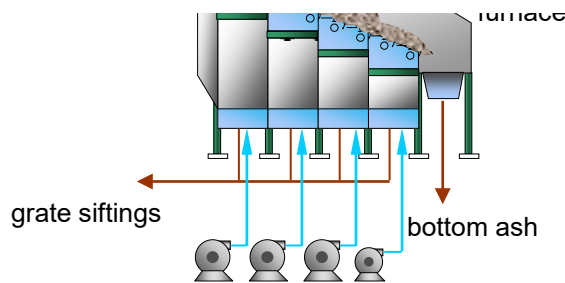

## Features

- Multiple primary air fans
- Secondary air injection at several levels
- Frequency controlled fans

## Advantages

- Optimised combustion air control
- Max. energy production
- Minimum electricity consumption
- High availability

# Steam boiler

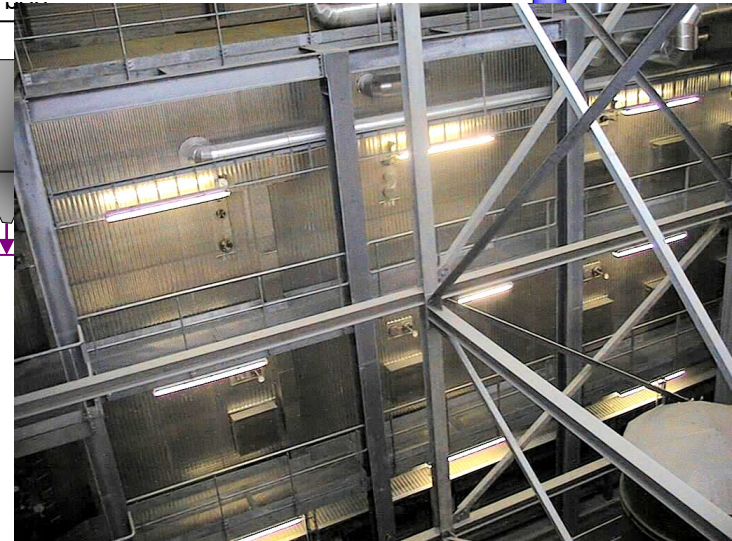
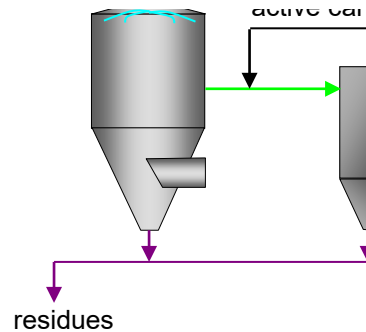
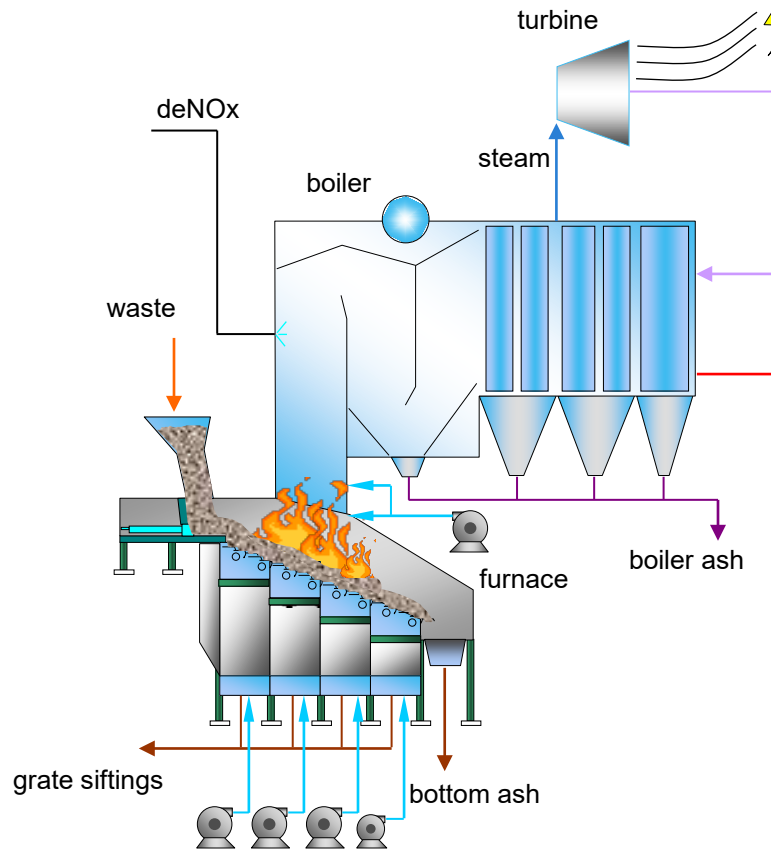

## Features

- Horizontal boiler
- T before final superheater < 650°C
- Steam conditions 400°C/40 bara
- Controlled specifications

## Advantages

- High availability
- Min. maintenance costs
- Min. corrosion problems
- High quality



# Boiler cleaning

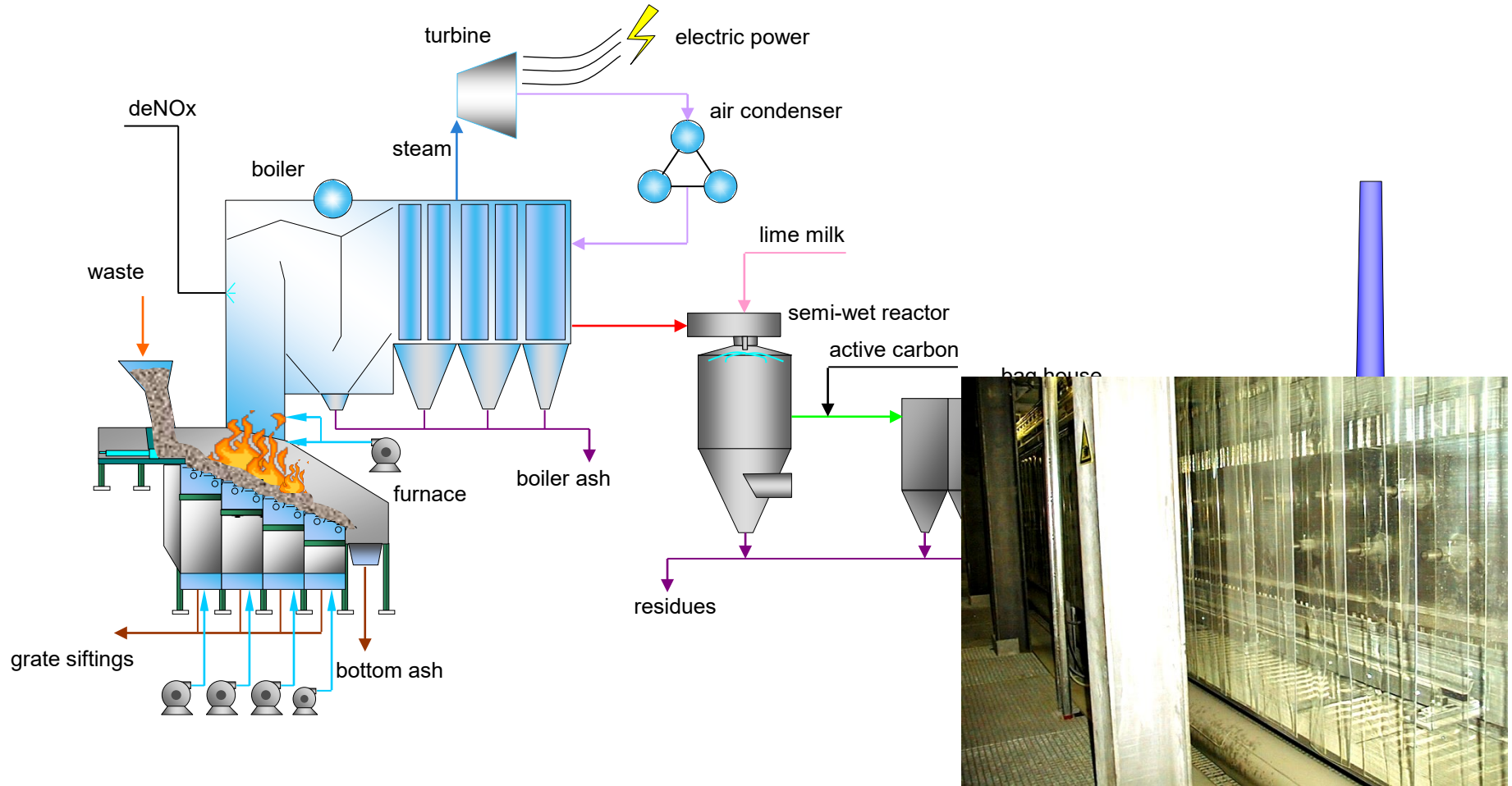

## Features

- Rapping system
- Externally mounted on cart
- Pneumatic hammers

## Advantages

- Efficient cleaning
- Reduced dioxin production
- Increased steam production
- Reduced maintenance costs

# Semi-wet scrubber (SDA)

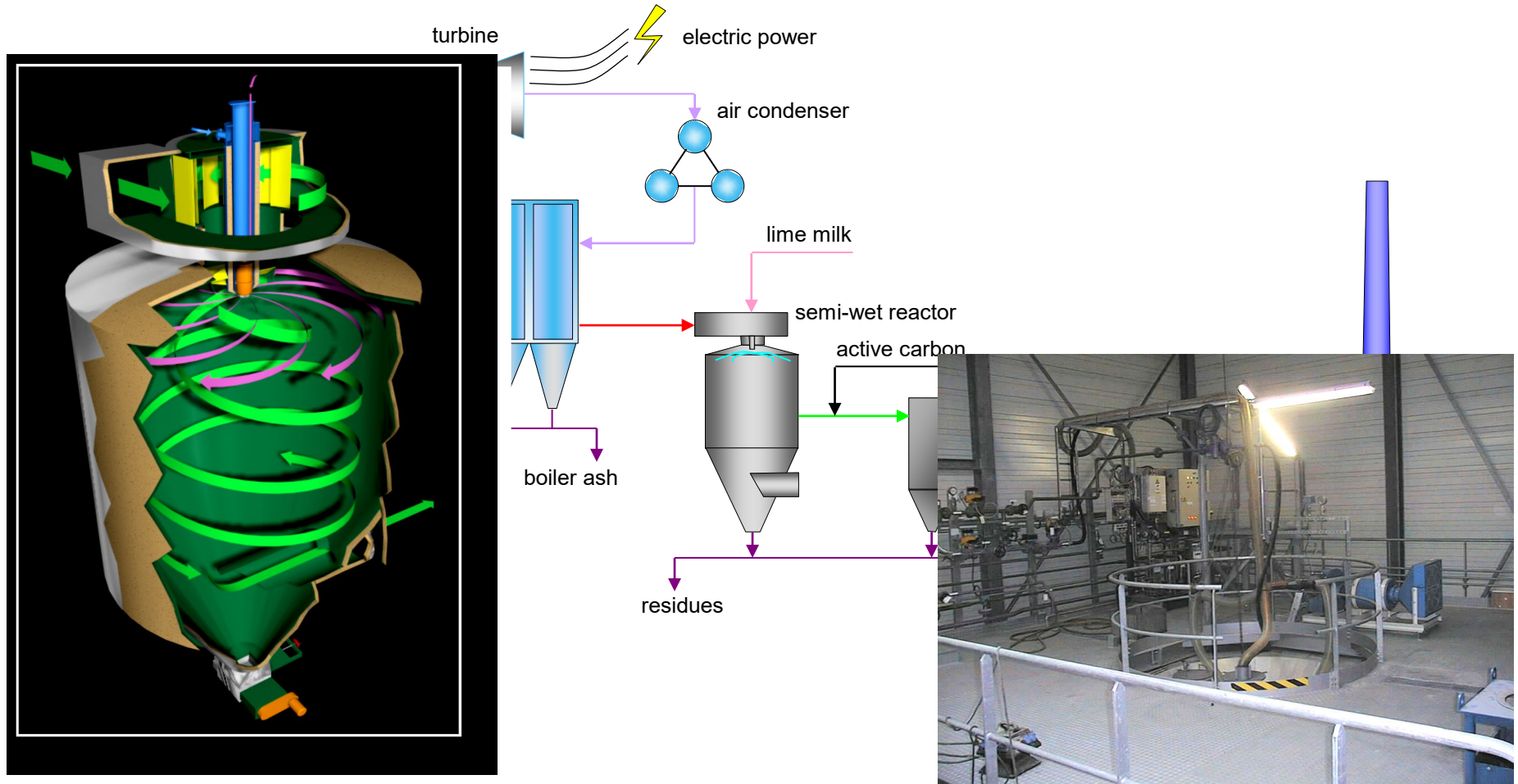

## Features

- Very high removal efficiency
- Long residence time
- Intense mixing of gases and slurry

## Advantages

- Reduced lime consumption
- Evolutionary system
- High availability

# Bag house – flue gasses

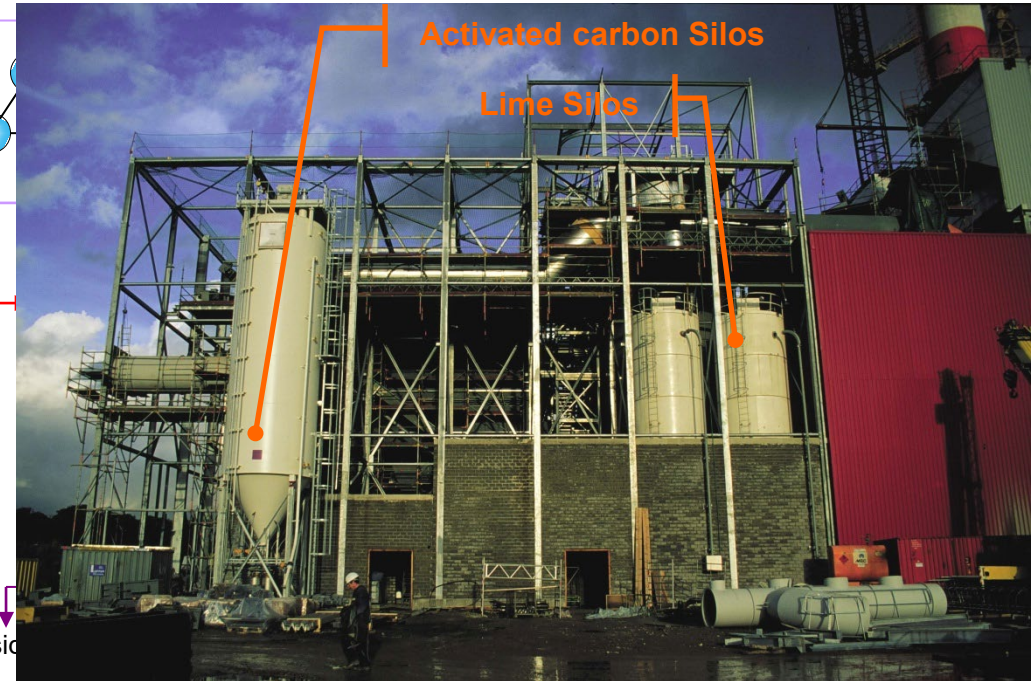
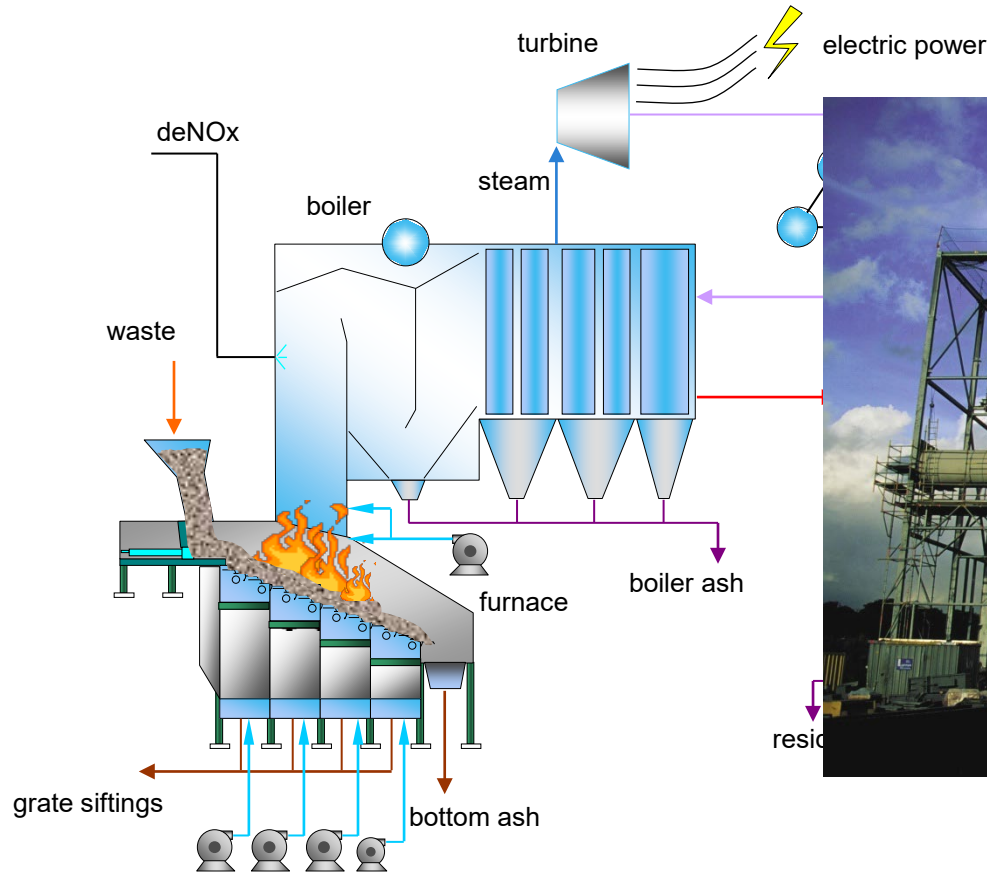

## Features

- Very high quality bag material
- Dedicated cleaning control
- High surface
- Walk in plenum

## Advantages

- Longer life time
- Higher cleaning efficiency
- Reduced wear, less elec. consumption
- Easier maintenance and bag repair

# Dioxins et furanes: experience

Antwerp plant: semi-wet + wet

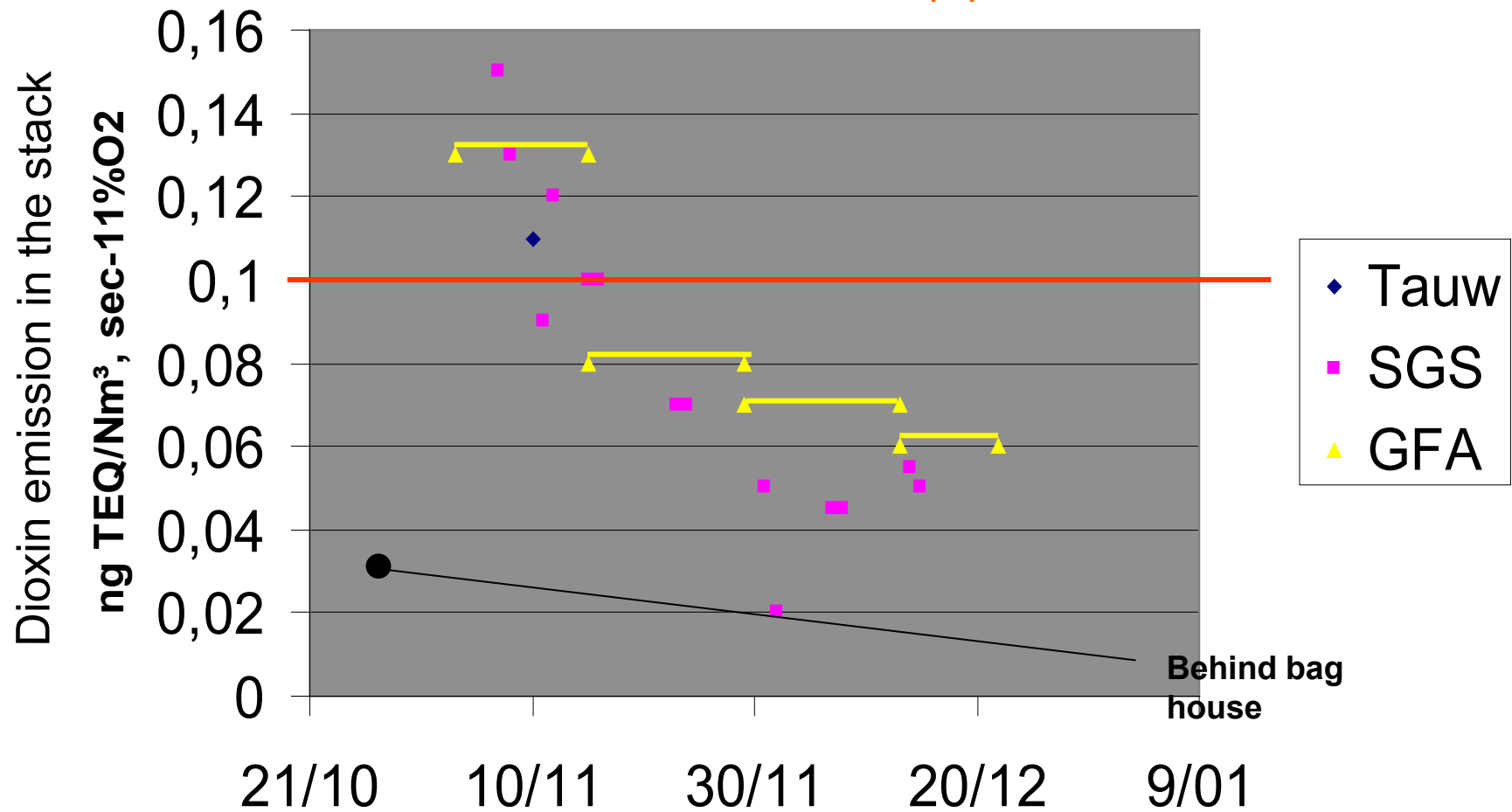



# Turbine

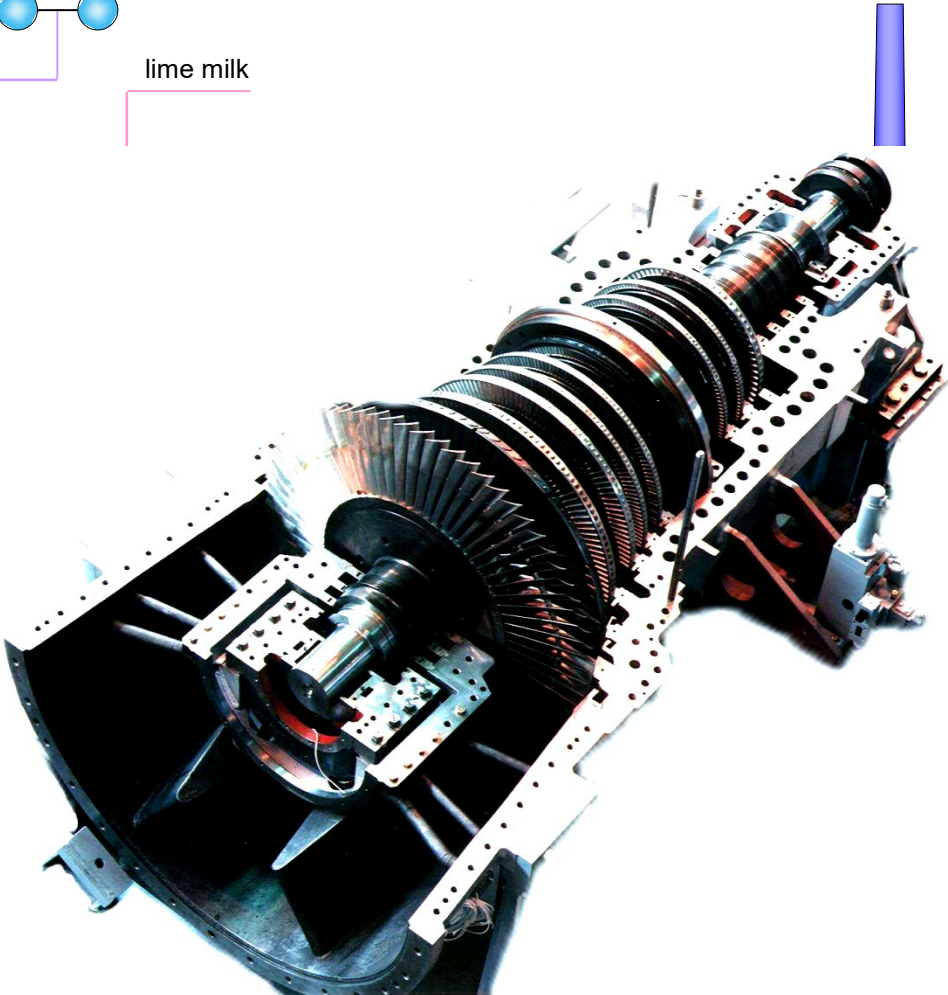
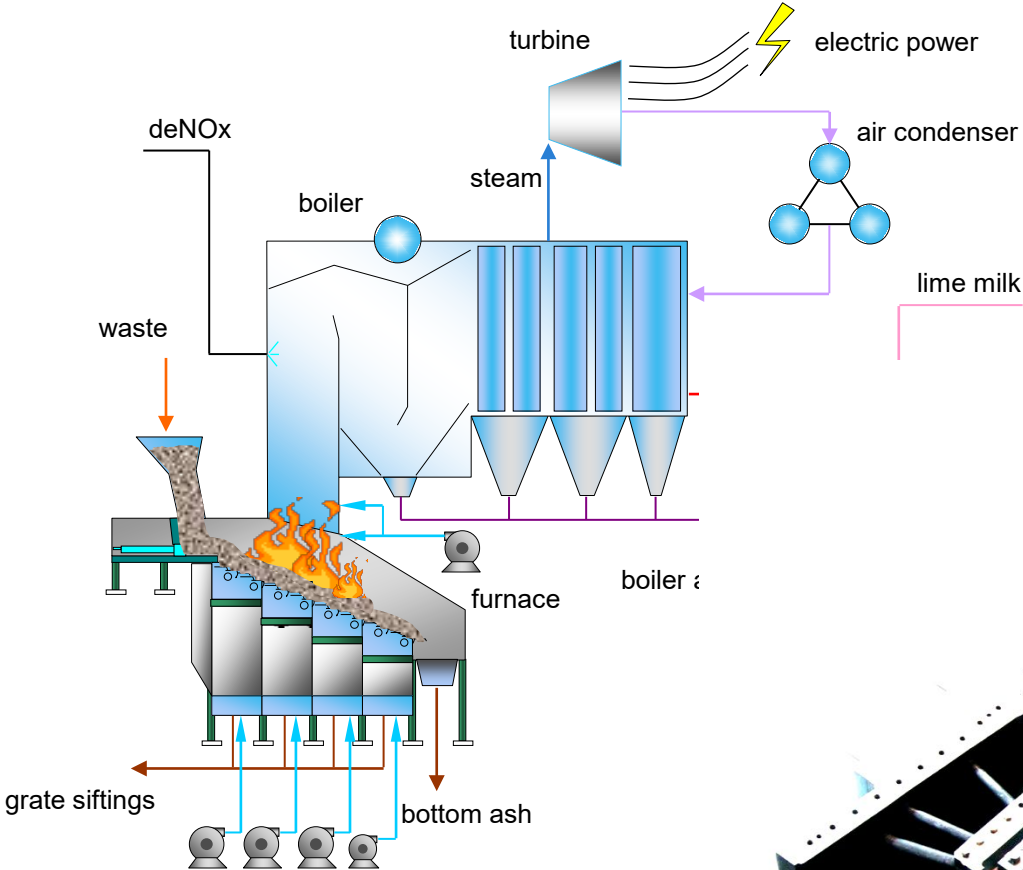

# Control system

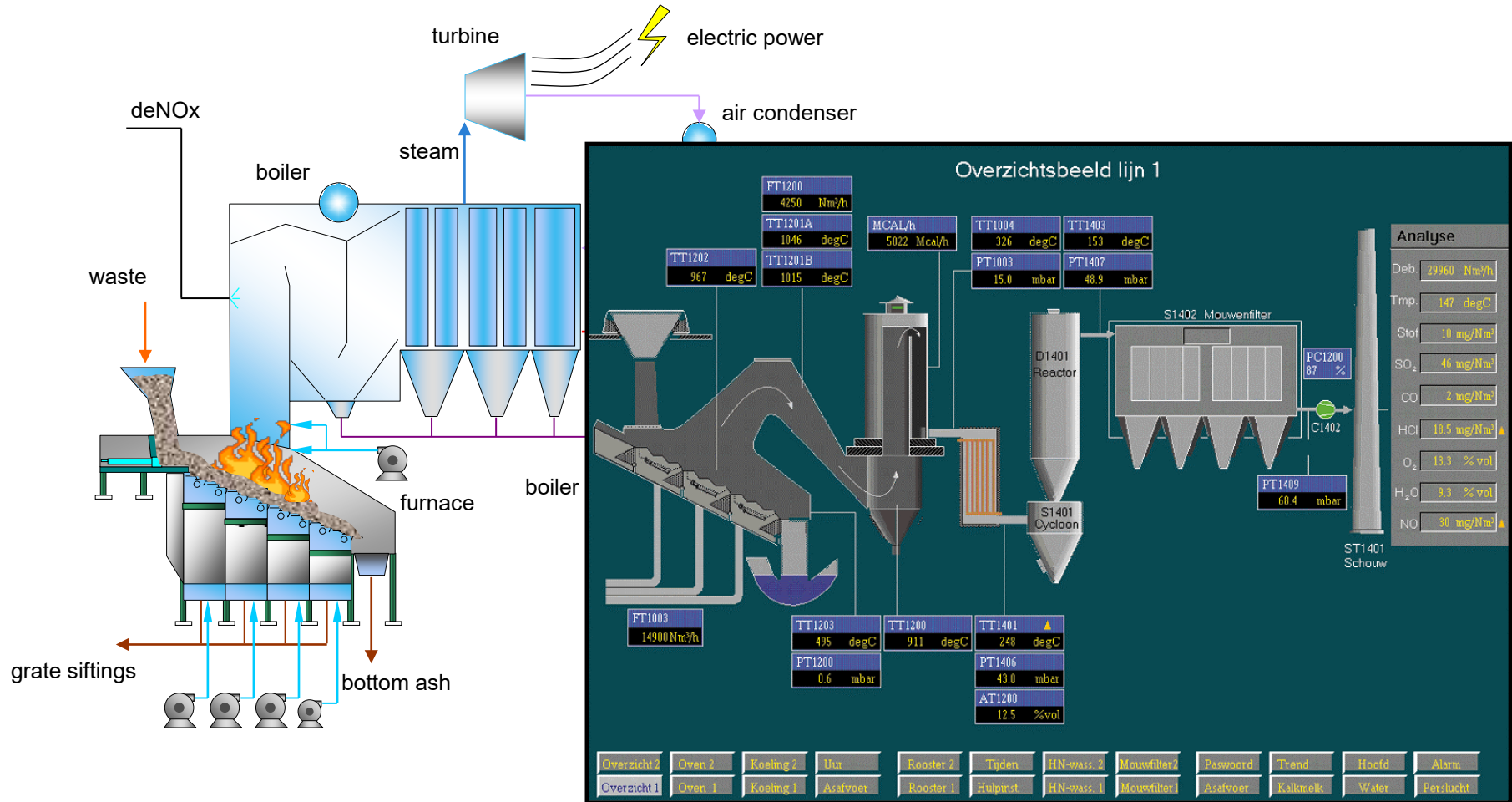

## Features

- Multiple functions: control, visualisation, data logging, maintenance, operator manual, consumables
- Own team

## Advantages

- Stable operation yields more power
- Frees operators
- More steam, better emissions
- Preventive maintenance



# The operators & neighbours



: power

condenser

lime milk

semi-wet reactor

active carbon

bag house

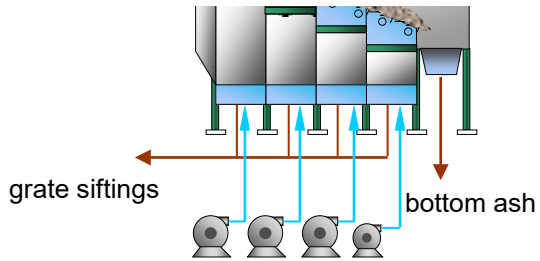
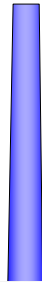

residues



# Some of the references with partners

## INDAVER RO1&2

**Client:** INDAVER (Flemish Government, BASF, Monsanto, Bayer,...)

**Location:** Antwerp (Belgium)

**Capacity:** 2 x 100.000 TPA  
2 x 40 MWth

**Steam:** 90 TPH at 400°C, 40 bar

**Energy:** electricity 19 MWe

**LHV :** 10.8 MJ/kg (design), 8-14 MJ/kg (range)

**FG treatment:** Semi-wet, active carbon

**Contract:** Turn-key

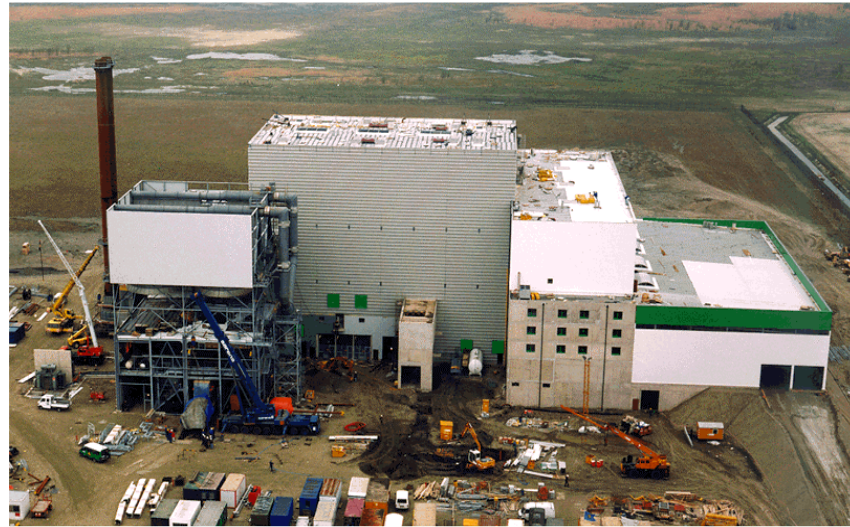

# INDAVER RO3

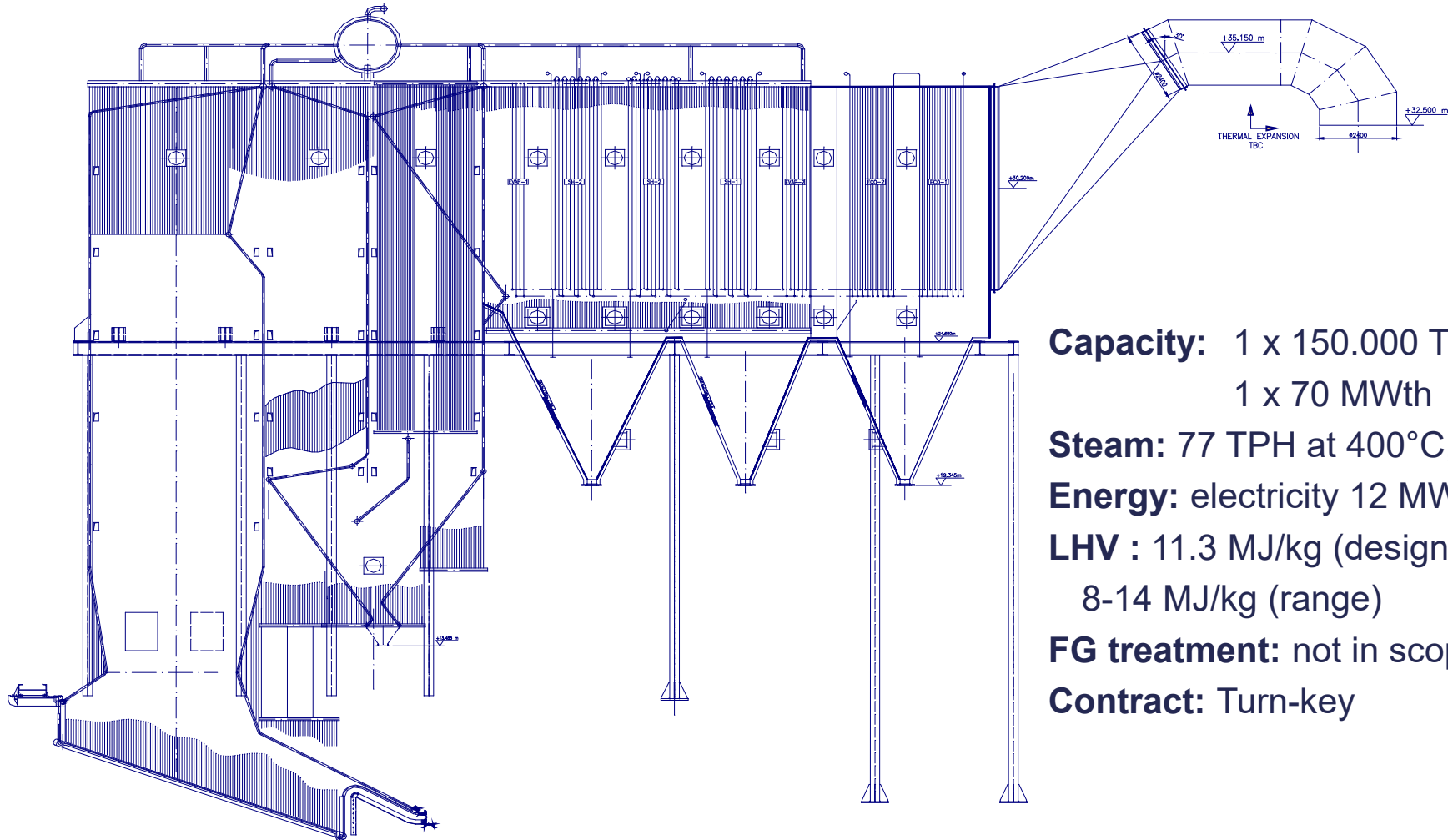

**Capacity:** 1 x 150.000 TPA  
 1 x 70 MWth  
**Steam:** 77 TPH at 400°C, 40 bar  
**Energy:** electricity 12 MWe  
**LHV :** 11.3 MJ/kg (design),  
 8-14 MJ/kg (range)  
**FG treatment:** not in scope  
**Contract:** Turn-key









**CONTACTS*****WSB Energy Holding BV***

Oranjeplein 44A, 6224 KK,  
Maastricht, The Netherlands

***EEMAXX INVESTMENTS BV***

Oranjeplein 44A, 6224 KK,  
Maastricht, The Netherlands  
Director Francesco D'Alessandro

***KREN Operations Ltd***

Georgiou Karaiskaki 19  
Roussos Building - Office 1C - Agia Triada – Area  
3032, Limassol, Cyprus

t +357 99 49 84 52 - fax: +357 25 35 00 42

Director Leon Vankan

***Eemaxx Services srl***

Operations and Management  
Pontecagnano Faiano (SA) Cap 84098 - Italia  
Via Lucania SNC Centro Direzionale Il Granaio  
t +39 089 995 8402 - m+39 392 921 4682

Director Francesco D'Alessandro

***Eemaxx Engineering srl***

Engineering  
Bologna Cap 40138 - Italia  
Via Giuseppe Massarenti, 177/5  
t +39 051 4119692 - m+39 346 094 3336  
Director Giuseppe D'alessandro

***ESCO Eemaxx Innovation srl***

Bologna Cap 40138 - Italia  
Via Giuseppe Massarenti, 177/5  
t +39 051 4119692 - m+39 392 921 4682  
Director Francesco D'Alessandro



Eemaxx - WSB Group

**Thank you for your attention!**

31 July 2021